

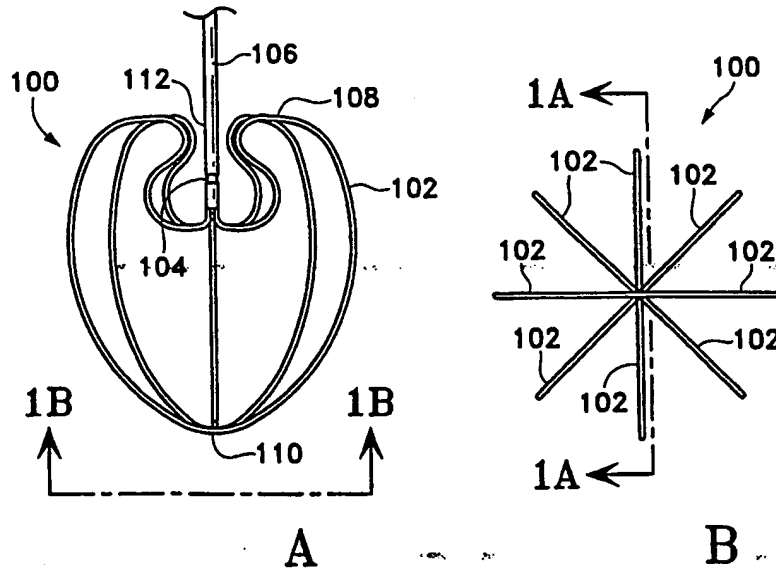

INTERNATIONAL APPLICATION PUBLISHED UNDER THE PATENT COOPERATION TREATY (PCT)

<p>(51) International Patent Classification ⁶ : A61B 17/12</p>	<p>A1</p>	<p>(11) International Publication Number: WO 99/08607 (43) International Publication Date: 25 February 1999 (25.02.99)</p>
<p>(21) International Application Number: PCT/US98/16367 (22) International Filing Date: 4 August 1998 (04.08.98) (30) Priority Data: 60/055,566 13 August 1997 (13.08.97) US 09/126,705 30 July 1998 (30.07.98) US (71) Applicant (for all designated States except US): TARGET THERAPEUTICS, INC. [US/US]; 47201 Lakeview Boulevard, Fremont, CA 94537-5120 (US). (72) Inventors; and (75) Inventors/Applicants (for US only): KEN, Christopher, G., M. [US/US]; 652 West Hillsdale Boulevard, San Mateo, CA 94403 (US). HAN, Thuzar, K. [US/US]; 37620 Murietta Terrace, Fremont, CA 94587 (US). HUI, Matthew, Ying-wing [US/US]; 799 Golden Creek Terrace, San Jose, CA 95111 (US). HO, Liem [VN/US]; 2235 California Street #157, Mountain View, CA 94040 (US). (74) Agents: WHEELLOCK, E., Thomas et al.; Morrison & Foerster LLP, 755 Page Mill Road, Palo Alto, CA 94304-1018 (US).</p>		<p>(81) Designated States: AL, AM, AT, AU, AZ, BA, BB, BG, BR, BY, CA, CH, CN, CU, CZ, DE, DK, EE, ES, FI, GB, GE, GH, GM, HR, HU, ID, IL, IS, JP, KE, KG, KP, KR, KZ, LC, LK, LR, LS, LT, LU, LV, MD, MG, MK, MN, MW, MX, NO, NZ, PL, PT, RO, RU, SD, SE, SG, SI, SK, SL, TJ, TM, TR, TT, UA, UG, US, UZ, VN, YU, ZW, ARIPO patent (GH, GM, KE, LS, MW, SD, SZ, UG, ZW), Eurasian patent (AM, AZ, BY, KG, KZ, MD, RU, TJ, TM), European patent (AT, BE, CH, CY, DE, DK, ES, FI, FR, GB, GR, IE, IT, LU, MC, NL, PT, SE), OAPI patent (BF, BJ, CF, CG, CI, CM, GA, GN, GW, ML, MR, NE, SN, TD, TG). Published With international search report.</p>

(54) Title: DETACHABLE ANEURYSM NECK BRIDGE



(57) Abstract

This is a device for bridging the neck of either a wide-necked or narrow-necked aneurysm in the vasculature. In general, it is a device used to stabilize the presence of vaso-occlusive devices (such as helically wound coils) in the aneurysm. The device preferably is delivered by a core wire which terminates in an electrolytically severable joint. The core wire will often be insulated. The retainer assembly itself is also attached to the electrolytic joint and typically has a number of array elements which are intended to be resident within the aneurysm after the device is deployed from the distal end of a catheter. After deployment of this retainer, the aneurysm is at least partially filled with a vaso-occlusive device such as helically wound coils.

FOR THE PURPOSES OF INFORMATION ONLY

Codes used to identify States party to the PCT on the front pages of pamphlets publishing international applications under the PCT.

AL	Albania	ES	Spain	LS	Lesotho	SI	Slovenia
AM	Armenia	FI	Finland	LT	Lithuania	SK	Slovakia
AT	Austria	FR	France	LU	Luxembourg	SN	Senegal
AU	Australia	GA	Gabon	LV	Latvia	SZ	Swaziland
AZ	Azerbaijan	GB	United Kingdom	MC	Monaco	TD	Chad
BA	Bosnia and Herzegovina	GE	Georgia	MD	Republic of Moldova	TG	Togo
BB	Barbados	GH	Ghana	MG	Madagascar	TJ	Tajikistan
BE	Belgium	GN	Guinea	MK	The former Yugoslav Republic of Macedonia	TM	Turkmenistan
BF	Burkina Faso	GR	Greece			TR	Turkey
BG	Bulgaria	HU	Hungary	ML	Mali	TT	Trinidad and Tobago
BJ	Benin	IE	Ireland	MN	Mongolia	UA	Ukraine
BR	Brazil	IL	Israel	MR	Mauritania	UG	Uganda
BY	Belarus	IS	Iceland	MW	Malawi	US	United States of America
CA	Canada	IT	Italy	MX	Mexico	UZ	Uzbekistan
CF	Central African Republic	JP	Japan	NE	Niger	VN	Viet Nam
CG	Congo	KE	Kenya	NL	Netherlands	YU	Yugoslavia
CH	Switzerland	KG	Kyrgyzstan	NO	Norway	ZW	Zimbabwe
CI	Côte d'Ivoire	KP	Democratic People's Republic of Korea	NZ	New Zealand		
CM	Cameroon			PL	Poland		
CN	China	KR	Republic of Korea	PT	Portugal		
CU	Cuba	KZ	Kazakstan	RO	Romania		
CZ	Czech Republic	LC	Saint Lucia	RU	Russian Federation		
DE	Germany	LI	Liechtenstein	SD	Sudan		
DK	Denmark	LK	Sri Lanka	SE	Sweden		
EE	Estonia	LR	Liberia	SG	Singapore		

DETACHABLE ANEURYSM NECK BRIDGE

5

CROSS REFERENCE TO RELATED APPLICATION

This application is a conversion to regular U.S. patent application of provisional U.S. application number 60/055,566 filed August 13, 1997.

FIELD OF THE INVENTION

10

This invention is a device for bridging the neck of either a wide-necked or narrow-necked aneurysm in the vasculature. In general, it is a device used to stabilize the presence of vaso-occlusive devices such as helically wound coils in the aneurysm. The vaso-occlusive coils are preferably delivered by a core wire which is linked to the coils by an electrolytically severable joint. The core wire will often be insulated. The retainer assembly itself is also attached to another electrolytically severable joint and typically has a number of array elements which are intended to be resident within the aneurysm after the device is deployed from the distal end of a catheter. After deployment of this retainer, the aneurysm is at least partially filled with a vaso-occlusive device such as helically wound coils.

15

20

BACKGROUND OF THE INVENTION

Different implantable medical devices have been developed for treating a number of ailments associated with body lumens. In particular, occlusive devices are useful in filling vascular or other body spaces. Some body spaces, such as vascular aneurysms, are formed due to a weakening in the wall of an artery. Often these aneurysms are the site of internal bleeding and, catastrophically, the site of strokes. A variety of different embolic agents are known as, at least arguably, suitable for treatment of these openings. These treatments are commonly known as "artificial vaso-occlusion."

25

30

One such class of embolic agents includes injectable fluids or suspensions, such as microfibrillar collagen, various polymeric beads, and polyvinylalcohol foam. These polymeric agents may additionally be crosslinked (sometimes *in vivo*) to extend the

persistence of the agent at the vascular site. These agents are often introduced into the vasculature through a catheter. After such introduction, materials there form a solid space-filling mass. Although some provide for excellent short term occlusion, many are thought to allow vessel recanalization due to absorption of polymer into the blood. Another
5 procedure in which a partially hydrolyzed polyvinylacetate (PVA) is dissolved in an ethanol solvent and injected into a desired vascular site is found in Park et al. (attorney docket no. 29025-20112.00) U.S. Patent Application Serial No. 08/734,442, filed October 17, 1996, for "LIQUID EMBOLIC AGENTS".

Other materials such as hog hair and suspensions of metal particles have also been
10 suggested and used by those wishing to form occlusions.

Other materials including polymer resins, typically cyanoacrylates, are also employed as injectible vaso-occlusive materials. These resins are typically mixed with a radio-opaque contrast material or are made radio-opaque by the addition of a tantalum powder. Their use is fraught with problems in that placement of the mixture is quite
15 difficult. These materials are ones which crosslink with the human body. Inadvertent embolisms in normal vasculature (due to the inability of controlling the destination of the resins) is not uncommon. The material is also difficult or impossible to retrieve once it has been placed in the vasculature.

Over the past few years, advancements in the artificial occlusions of vessels and
20 aneurysms have occurred due to the delivery and implantation of metal coils as vaso-occlusive devices. Implantable metal coils that are useful as artificial occlusion devices in vasculature lumens or aneurysms are herein referred to as "vaso-occlusions coils."

Vaso-occlusions coils are generally constructed of a wire, usually made of a metal or metal alloy, that is wound to a helix. Many such devices are introduced to the selected
25 target site through a catheter in a stretched linear form. The vaso-occlusive device assumes an irregular shape upon discharge of the device from the distal end of the catheter a variety of vaso-occlusive coils and braids are known. For instance, U.S. Patent No. 4, 994,069, to Ritchart et al., shows a flexible, preferably coiled, wire for use in small vessel vaso-occlusion. Unlike vaso-occlusive coils used prior to that time, Ritchart taught a coil
30 which is fairly soft and is delivered to the site using a pusher within a catheter lumen.

Upon discharge from the delivery catheter, the coil may undertake any of the number of random or regular configurations used to fill the site. The coils are used for small vessel

sites, e.g., 0.5-6 mm in diameter. The coils themselves are described as being between 0.010 and 0.030 inches in diameter. The length of the coil wire is typically 15 to 20 times the diameter of the vessel to be occluded. The wire used to make up the coils may be, for instance, 0.002 to 0.006 inches in diameter. Tungsten, platinum, and gold threads or wires are said to be preferred. These coils have a variety of benefits including the fact that they are relatively permanent, they may be easily imaged radiographically, they may be located at a well defined vessel site, and they can be retrieved.

It is common that these vaso-occlusive devices be delivered through microcatheters such as the type disclosed in U.S. Patent No. 4,739,768, to Engelson. These microcatheters track a guidewire to a point just proximal or within the desired site for occlusion. The coil is advanced through the microcatheter (once the guidewire is removed) and out the distal end hole so to at least partially fill the selected space and create an occlusion.

In addition to vaso-occlusion devices or coils having predetermined secondary shapes that dictate in part their space filling mechanism, other vaso-occlusive coils have been disclosed that take on random shapes when expelled from a delivery sheath. One such type is a vaso-occlusive coil often referred to as "a liquid coil". One example of such a vaso-occlusive coil is disclosed in pending U.S. Patent Application Serial No. 08/413,970, filed March 30, 1995. This document describes a very soft and flexible coil which is flow-injectable through a delivery catheter using, e.g., saline solution.

In addition to the various types of space filling mechanisms and geometries of vaso-occlusive coils, other particularized features of coil designs, such as mechanisms for delivering vaso-occlusive coils through delivery catheters and implanting them in a desired occlusion site, have also been described. The examples of categories of vaso-occlusive coils based upon their delivery mechanisms include pushable coils, mechanically detachable coils, and electrolytically detachable coils.

One example of the type of vaso-occlusive coil referred to above as the "pushable coil" is disclosed in Ritchart et al., discussed above. Pushable coils are commonly provided in a cartridge and are pushed or "plunged" from the cartridge into a delivery catheter lumen. A pusher advances the pushable coil through and out of the delivery catheter lumen and into the site for occlusion.

Mechanically detachable vaso-occlusive devices are typically integrated with a pusher rod and are mechanically detached from the distal end of that pusher after exiting a delivery catheter. Examples of such mechanically detachable vaso-occlusive coils are found in U.S. Patent No. 5,261,916 to Engelson or U.S. Patent No. 5,250,071 to Palermo.

5 Finally, examples of electrolytically detachable vaso-occlusive devices may be found in U.S. Patent Nos. 5,122,136 and 5,354,295, each to Guglielmi et al. In these devices, the vaso-occlusive portion of the assembly is attached to a pusher via a small electrolytically severable joint. The electrolytically severable joint is severed by the placement of an appropriate voltage on the core wire. The joint erodes in preference either
10 to the vaso-occlusive device itself or to the pusher core wire. The core wire is often simply insulated to prevent the electrolytic response caused by the imposition of electrical current.

 Further improvement upon the electrolytical detachment mechanism described just is found in U.S Patent Application Serial No. 08/205,512, filed March 3, 1994. This document describes superimposing a modest alternating current upon the direct current
15 signal. A sensing circuit monitors the alternating current as an indicator of the progression of coil detachment.

 Improvements in enhancing the thrombogenic or other occlusive tissue response to metal coils has also been disclosed. For example, vaso-occlusive coils having fibers attached thereto are known -- see, for example, U.S. Patent No. 5,226,911 to Chee et al.

20 Each of the devices described above may be used in the treatment by occlusion of aneurysms. As noted above, aneurysms present particularly acute medical risk due to the dangers of potential rupture of the thin wall inherent in such an aneurysm. Occlusion of aneurysms by the use of vaso-occlusive coils without occluding the adjacent artery is a special challenge and is a desirable method of reducing such risk of rupture.

25 As noted above, the use of vaso-occlusive coils in treating aneurysms is widespread. These vaso-occlusive devices are placed in an aneurysm in the following fashion. A microcatheter is initially steered into or adjacent to the entrance of an aneurysm, typically aided by the use of a steerable guidewire. The wire is then withdrawn from the micro catheter lumen and replaced by the vaso-occlusive coil. The vaso-
30 occlusive coil is advanced through and out of the microcatheter. Desirably being completely delivered into the aneurysm. After, or perhaps, during, delivery of such a coil into the aneurysm, there is a specific risk that a portion of the coil might migrate out of the

aneurysm entrance zone and into the feeding vessel. The presence of such a coil in that feeding vessel may cause the undesirable response of causing an occlusion there. Also, there is a quantifiable risk that the blood flow in the vessel and aneurysm may induce movement of the coil farther out of the aneurysm, resulting in a more developed embolus in the patent vessel.

One type of aneurysm, commonly known as a "wide neck aneurysm" is known to present particular difficulty in the placement and retention of vaso-occlusive coils. Wide neck aneurysms are herein referred to as aneurysms of vessel walls having a neck or a "entrance zone" from the adjacent vessel, which entrance zone has a diameter that either: (1) is at least 80% of the largest diameter of the aneurysm; or (2) is clinically observed to be too wide effectively to retain vaso-occlusive coils that are deployed using the techniques discussed above.

Furthermore, vaso-occlusive coils lacking substantial secondary shape strength may be difficult to maintain in position within an aneurysm no matter how skillfully they are placed.

There are few disclosed devices for maintaining the presence of vaso-occlusive coils within an aneurysm. One such device is shown in U.S. Patent No. 08/690,183, filed July 26, 1996 for "ANEURYSM CLOSURE DEVICE ASSEMBLY" (attorney docket 29025-20162.00). That document describes a number of devices all which are said to be placed within the lumen of a feed vessel exterior to the aneurysm so to retain coils within the aneurysm cavity. That is to say that the retainer device is released in the vessel exterior to the aneurysm. The device is held in place via the presence of radial pressure on the vessel wall. After the device is released and set in an appropriate place, a microcatheter is inserted into the lumen behind the retainer device and the distal end of the catheter is inserted into the aneurysm cavity. One or more vaso-occlusive devices is introduced into the aneurysm cavity. The retainer device maintains the presence of those vaso-occlusive devices within the aneurysm no matter whether the aneurysm is a large mouth aneurysm or not.

Another device for closing an aneurysm is found in U.S. Patent Application No. 08/588,195, filed January 18, 1996 for "ANEURYSM CLOSURE METHOD" (attorney docket number 29025-20136.00). In this procedure, a vaso-occlusive device such as a coil or braid has on its outer surface a polymeric composition which may be reformed or

solidified *in situ* within the human body. The device is simply inserted into the aneurysm and the polymer is then reformed, e.g., by the application of light, to melt or otherwise to reform the polymer exterior to the vaso-occlusive device. The vaso-occlusive device then sticks to itself at its various sites of contact and forms a rigid whole mass within the aneurysm.

There are a variety of other vaso-occlusive coils and devices which may be specified herein. The material provided above is only exemplary of the patents and publications dealing with such devices. No coil retainer device of the structure described herein is seen in any of the references described above.

SUMMARY OF THE INVENTION

This invention includes an implantable medical device useful for retaining other occlusion devices at an occlusion site, such as an aneurysm, and includes related methods of introducing and installing that medical device at the occlusion site. Combinations of the retainer device and its included vaso-occlusive material or device are also an aspect of the invention. In particular, the invention involves an implantable retainer which is deliverable through an elongated tubular delivery device such as a vascular catheter. The implantable retainer typically includes a core wire having both a proximal end and a distal end. At the distal end is a joint which extends between the distal end of that core wire and a number of array elements. The joint is electrolytically severable upon application of a suitable current to the joint. The joint is comparatively more electrolytically dissolvable when a current is applied than any of the rest of the implantable retainer components. Finally the retainer assembly itself has a number of array elements which are of a shape (a first or delivery shape) which is deployable through a delivery catheter and, upon exit from the distal end of that catheter, readily assumes a secondary shape desirably conforming to the interior shape of the aneurysm catheter. Electrolysis of the severable joint then permits placement of the retainer assembly in the aneurysm and removal of the attached delivery apparatus. Placement of the vaso-occlusive device to be retained in the aneurysm may then be had by simply introducing the vaso-occlusive device and its delivery tubular member between the array elements in the aneurysm.

The array elements themselves may be loops or may be arms which simply extend from the joint into the aneurysm cavity. It is within the scope of this invention that the

retainer assembly include a number of "exterior" array members which, in general, extend radially from the region of the joint and are intended to remain in the feed vessel -- not in the aneurysm -- after deployment. These exterior loops define, with the interior array elements an annular area between them into which the rim or mouth of the aneurysm may fit.

The various portions of the device may be made to be radio-opaque by the choice of materials or by such other procedures as by wrapping the components in a radio-opaque wire or ribbon.

BRIEF DESCRIPTION OF THE DRAWINGS

Figures 1A and 1B are respectively a side view and a top view of a variation of the inventive aneurysm retainers.

Figures 2A and 2B are respectively side view and a top view of a variation of the inventive aneurysm retainers.

Figures 3A and 3B are respectively a top view and a side view of the inventive aneurysm retainers including in this instance arrays placed outside the aneurysm.

Figures 4A and 4B are show respectively a top view and a side view of the inventive aneurysm retainer.

Figures 5A and 5B show respectively a side view and top view of a variation of the inventive aneurysm retainer.

Figure 6A and 6B show respectively a side view and top view of a variation of the inventive aneurysm retainer in which the array members are not loops.

Figures 7A and 7B are respectively a side view and top views of a variation of the inventive aneurysm retainer.

Figure 8 is a close-up, partial cross-section of an electrolytic joint suitable for use in the invention.

Figure 9 is a partial cross-section of the electrolytic joint suitable for use in this invention.

Figure 10 shows a close-up partial sectional view of an array member wrapped with a radio-opaque wire, also suitable for use in this invention.

Figures 11A to 11E show a method of deploying, a device made according to this invention and the vaso-occlusive devices therein.

DESCRIPTION OF THE INVENTION

This invention involves a device and procedure for solving the problem of stabilizing the structure and placement of vaso-occlusive devices when they are placed in an aneurysm. These retaining devices prevent the migration of one or more occlusion devices such as coils from a target occlusion site, by forming a barrier at the entrance zone to the target site from a feeding vessel. The remainder of the retainer device which is remote from the mouth generally provides stability to the portion of the device which is in the mouth of the aneurysm.

Figures 1A and 1B show typical but simple variation of the device in which the retainer assembly (100) has a shape which approximates that of the aneurysm into which it is placed. Specifically, the retainer device (100) has a plurality of array elements (102) or "interior" array elements (102) which extend from an electrolytic joint (104) and form a loop which comes around to join itself back in the vicinity of electrolytic joint (104). It is, of course, permissible to use joints other than electrolytic joints in place of (104), e.g., joints which rely upon mechanical joining for structural certainty. However, joint (104) is desirably electrolytically severable because such joints are very functionally flexible in their deployment. That is to say, that should the aneurysm retainer somehow be misplaced, the fact that core wire (106) can be used to withdraw this device back into its delivery catheter or other suitable delivery tubular member, is a very big benefit.

Figure 1A, a side view of the inventive retainer (100), shows another aspect of this invention which is significant. In this variation, array member (102) has a proximal end (108) and a distal end (110). Similarly, as a convention here, core wire (106) has a distal end (112) which is just proximal of the electrolytic joint (104). Now as may be seen from Figure 1A, joint (104) and core wire distal end (112) are both distally placed from the proximal end of the retainer assembly (108). This configuration has at least two benefits. First of all, the joint itself is not placed in the feed artery and should not cause the creation of an embolus in that vessel with the danger of subsequent blockage. Furthermore, the plurality of array wires (as may be shown from the top view in Figure 1B) form what might be characterized as a skeletal funnel at the top of the retainer device (100) and consequently in the aneurysm itself, placement or re-placement of the catheter in the

retainer device so to permit introduction of the vaso-occlusive member (not shown) into the interior volume of the aneurysm retainer device is simplified.

This variation of the invention as well as the others discussed below, are delivered through a tubular member such as a catheter. The shape of the device shown in Figure 1A is the so-called secondary shape found after the retainer device (100) has been pushed from the distal end of the delivery. The retainer device (100) generally has a relatively linear shape as is pushed through catheter. This primary or delivery shape is essentially the shape of the interior of the catheter during the delivery step. After deployment, the device assumes its secondary shape as is seen in Figure 1A..

To undergo such massive changes in shape, it is usually preferable that the interior array elements (102) be produced of material such as a superelastic alloy. Superelastic or pseudoelastic shape recovery alloys are well known in this art. For instance, US Patent Nos. 3,174,851; 3,351,463; and 3,753,700 each describe one of the more well known superelastic alloys, also known as Nitinol. These alloys are characterized by their ability to be transformed from an austenitic crystal structure to a stress-induced martensitic (SIM) structure at certain temperatures and then return elastically to the austenitic shape when the stress is removed. These alternating crystal structures provide the alloy with its superelastic properties. The alloy mentioned in the three patents just above, is a nickel-titanium alloy. It is readily commercially available and undergoes the austenitic-SIM-austenitic transformation in a variety of temperatures between -20°C and +30°C.

These alloys are especially suitable because of their capacity to recover elastically - almost completely -- to the initial configuration once the stress is removed. Typically, in these services, there is little plastic deformation even at relatively high strains. This allows the retainer device (100) to undertake substantial bends both as it is collapsed to enter the tubular delivery device and as it undertakes further bending in passing through turns in the vasculature. In spite of this bending, it returns to its original shape once the bend has been traversed without retaining a kink or a bend.

Of the superelastic alloys currently available, we consider a preferred material to be nominally $50.6 \pm 2\%$ nickel and most of the remainder, titanium. Up to about 5% of the alloy may be another member of the iron group of metals, particularly chromium and iron. The alloy shouldn't contain more than about 500 parts per million of oxygen, carbon, or

nitrogen. The transition temperature of this material is not particularly important, but it should be reasonably below the typical temperature of the human body so to allow it to be in its austenitic phase during use. The diameter of the wires or ribbons making up the array elements preferably are smaller than about 0.010 inches in diameter. As will be discussed
5 below in conjunction with Figure 10, the typical superelastic alloy is not always completely visible under fluoroscopy. Consequently, it is often desirable to add some type of a covering to improve the radio-opacity of the device. Radio-opaque metals such as gold and platinum are well known.

Although we have discussed the concept that these devices are desirably made from
10 superelastic alloys, other metals may in certain circumstances be appropriate. Such metals include a number of the stainless steels and other highly elastic, if not superelastic alloys. Furthermore, it is within the scope of this invention that the array elements (102) be of polymeric material. Polymeric materials are somewhat easier to work with in forming the device and may also be suitable for maintaining the vaso-occlusive devices at an appropriate
15 site within the aneurysm. Such materials as polyethylene, polypropylene, polytetrafluoroethylene, various of the Nylons, and the like would be easily chosen by one having ordinary skill in this art for the purposes shown herein.

The electrolytic severable joint (104) may also be called a sacrificial link. Core wire (106) is typically coated with an electrical insulator which is not susceptible to
20 dissolution via electrolysis in blood or other ionic media. Suitable coatings for core wire (106) include such insulating materials as the polyfluorocarbons (e.g., Teflon), polyurethane, polyethylene, polypropylene, polyimides or other suitable polymeric materials. Sacrificial joint (104) is not coated with such an insulator and is of a material which is susceptible to electrolytic dissolution in blood. Joint (104) may be a simple un-
25 insulated continuation of, e.g., stainless steel core wire (106), which has been insulated proximally of the joint. It should also be apparent that the sacrificial joint (106) is more susceptible to electrolysis than are the array elements (102). Further discussion of construction of, placement of, and other physical details of such a joint may be found in U.S. Patent Nos. 5,122,136 to Guglielmi et al.; 5,354,295 to Guglielmi et al.; 5,624,449, to
30 Pham et al., and others.

Although the array elements (104) are generally shown to be regular and of the approximate same shape on each of the axis through the retainer device (100), such

obviously need not be the case. It is within the scope of this invention that the retainer assembly be irregular in shape so to fit the shape of an irregular aneurysm. Placement of such devices must be done with some care, but it is within the purview of one having ordinary skill in the art with some instruction.

5 Figure 2A shows another variation of the inventive retainer assembly (120) in which the array elements are of two different types. Array element (122) is of the same general shape as those shown in Figure 1A and Figure 1B. Array element (122) extends directly into the aneurysm. Array elements (124) are paired to extend axially from the region of the joint (104). These axially extending loops (124) are also intended to fit
10 within the aneurysm and provide directional stability to the placement of the retainer device (120). Only a single axial array element (122) is shown in Figures 2A and 2B. The invention is, obviously, not so limited. The generally perpendicular array elements (124) may have larger loops than those shown as well. Again, this device is situated in its secondary form so that the remainder (126) of any element attached formerly joint (104)
15 after dissolution by electrolysis of joint (104), will not extend into the feeder vessel for this aneurysm. This retainer assembly (120) may be used to help close an aneurysm which is of substantial length but nominal width.

 Figures 3A and 3B show still another variation of the inventive device (140). This variation shows one internal array member (142), although multiple array members may be
20 used. In addition, Figures 3A and 3B show a number of external array members (144) which are intended to remain outside of the aneurysm when the aneurysm is deployed. These exterior or outer array members (144) are of the same general makeup and material as those shown in the earlier discussed Figures.

 Although the overall configuration of this device (140) as shown in Figures 3A and
25 3B may be indented at the top in the same manner as the variations shown in Figures 1A, 1B, 2A, and 2B, this neck configuration is shown for purposes of completing the variations of this invention. The exterior array members (144) and the interior array member (142) may be attached to core wire (150) via a ferrule (146) perhaps by crimping or perhaps by welding the devices components together. An electrolytic joint (148) on core wire (150) is
30 also shown. This variation of the invention is less desirable because of the possibility that the ferrule member (146) can be present in the flowing artery.

Figures 4A and 4B show another variation of the inventive device (160) having another number of exterior array members (162). It should be noted out that in some instances where the back wall of the aneurysm is determined to be especially weak and the neck of the aneurysm is considered to be the strongest retention point, that device such as is shown in Figures 3A, 3B, 4A, and 4B is quite useful. The presence of a single loop array element (164) within the aneurysm may be of benefit.

Figures 5A and 5B show a very simple variation (170) of the inventive device. This variation is a simple pair of array members (172) to be placed within the aneurysm. It too has a joining element (174) which may be the site from which interior elements (174) extend. The core wire (176) extends inward from the joining element (174) much as in the other arrangements discussed above.

Figures 6A and 6B show an very simple variation (180) of the inventive device. In this variation (180), the array elements (182) extend away from the region of the joint (184) and perhaps the joining element (186) and do not form a loop extending to the bottom of the aneurysm. This device is shown as having a small surface coil (discussed in more detail with regard to Figure 10 below). In this variation, it may be typical that the ends of the array arms (182) farthest away from joint (184) form the contact regions with the aneurysm wall and therefore provide stability to this retainer device (180). That is to say that unlike the retainers discussed above, wherein the retainer is kept from movement by contact with multiple sites inside the aneurysm, this device may merely contact the farther-most walls of that aneurysm.

Figures 7A and 7B show another variation of, generally, both features of the Figure 6A and 6B device as well as those shown in Figures 1A, 1B, 2A, and 2B. That is to say that the inventive device (190) utilizes loops as array members (192) which may extend to the bottom of the aneurysm. The joint for electrolytic dissolution (194) is recessed into the proximal end of the device (190). The upper portions of the array wires (192) are covered with a radio-opaque wrap (196).

It should be understood that the secondary shapes of the devices shown in Figures 1A through 7B are secondary shapes which occur when the retainer device is placed in the open air — that is to say not within aneurysm. Any placement of these devices in a human body will likely cause the secondary shape to distort. The shape which

these devices actually take within an aneurysm, although preferably those shown in the drawings noted above, may not be as depicted.

Figure 8 shows a close-up partial sectional view of desirable electrolytic joint configuration. In Figure 8, the core wire (200) has over it, a plastic sleeve (202) which is cut at a bias or angle (204). The electrolytic joint (206) is small, discrete area which concentrates the flow of current into that area so to accelerate the dissolution of that joint. Preferably the region just proximal of the joint (208) is also covered with an insulator. Electrolytic joint (206) is placed as far distal as is reasonably possible during assembly so to prevent jagged edges and points after dissolution. In this variation, the joining block (210) is a plastic joint into which both the element (212) -- distal to joint (206) -- is embedded. Array members (214) are also shown and they are, as well, embedded in plastic junction member (210). This arrangement may provide some benefit, in that when an electric current is applied to core wire (200), there is no tendency for the current to flow into the array elements (214) because they are insulated by junction block (210). This is believed to accelerate the dissolution of joint (206).

Figure 9 shows another close-up partial sectional view of the distal end of core wire (200) with joint (206) and proximal covering (208). The major difference between the variation shown in Figure 8 and that shown in Figure 9 is that the array members (214) are crimped onto distal member (212), using a ferrule (220). Such a ferrule (220) may simply mechanically attach array members (214) to core wire (200) or additional joining arrangements, e.g., welding or the like may be employed. Although soldering is not typically desirable because of the potential creation of a ragged joint on the proximal end of distal element (212), in some circumstances it may be permissible to solder it as well.

Figure 10 shows a partial cut-away of an array arm (220) having an interior wire (222) and a radio-opaque coil (224) wrapped about its exterior. Exterior wire (224) may also be an exterior ribbon or the like, if such is a more pleasing variation to the designer using the teachings of this invention. Coil (224) is merely a radio-opacifier for the overall device (220).

This device may be deployed in the following manner. Figure 11A shows a berry aneurysm (200) emanating from the wall of an artery (202). A catheter (204) is shown having radio-opaque band (206) at its distal end. The distal end of catheter (204) extends into the mouth (208) of the aneurysm (200). Figure 11B shows a retainer device (212)

having a shape similar to those discussed above. This variation of the inventive retainer (212) has interior array members (214) and exterior array members (216). It should be also noted that the exterior array members (216) are exterior to the aneurysm (200) and the remaining array members (214) are interior to aneurysm (200). It should probably be
5 apparent that the various array members should not pinch the aneurysm in any very meaningful or deleterious way, lest some type of rupture occur.

In Figure 11C, it can be seen that the voltage has been applied to core wire (218), and the electrolytic joint has been dissolved. The core wire (218) is then withdrawn from catheter (204) and discarded. It may be also seen in Figure 11C that the region of the joint
10 adjacent the retainer device (212) is recessed out of the flow of artery (202).

In Figure 11D, catheter (204) has been re-introduced into the neck of aneurysm (200) and a number of vaso-occlusive devices -- in this case, coils (220) -- have been introduced into the volume formed by retainer assembly (212).

Figure 11E show the withdrawal of catheter (204) from the feed vessel with the
15 implantation of vaso-occlusive coils (220) and their stabilizing retainer (212) complete.

Many alterations and modifications may be made by those of ordinary skill in this art, without departing from the spirit and scope of this invention. The illustrated embodiments have been shown on for purposes of clarity and the example should not be taken as limiting the invention as defined in the following claims, which are intended to
20 include all equivalents, whether now or later devised.

WE CLAIM AS OUR INVENTION:

1. An implantable retainer, deliverable via an elongate tubular delivery device for retaining vaso-occlusive device in an aneurysm, comprising:

(a) a core wire having a proximal end and a distal end,

5 (b) a joint extending between the distal end of the core wire and at least one array element, said joint being electrolytically severable upon application of a suitable current to said joint, said joint being comparatively more susceptible to electrolytic severability than said core wire and said at least one array element, and

(c) a retainer assembly comprising said at least one array element, said
10 retainer assembly having a first delivery shape when retained within said elongate tubular delivery device and having a distal delivery end and a proximal delivery end, and a second deployed shape, different than first delivery shape, when said retainer assembly is not retained within said tubular delivery device and having a distal deployed and an proximal deployed end, said at least one array element
15 extending outwardly from said joint in said second deployed shape, and wherein after electrolytic severance from said core wire, said retainer assembly includes a residual joint.

2. The implantable retainer of Claim 1, wherein said core wire is covered with an
20 electrical insulation layer from near its proximal end to near its distal end.

3. The implantable retainer of Claim 1, wherein said at least one array element
comprise platinum.

25 4. The implantable retainer of Claim 1 wherein said at least one array elements
comprise tantalum.

5. The implantable retainer of Claim 1 wherein said at least one array element
comprise stainless steel.

30 6. The implantable retainer of Claim 1 wherein said at least one array element
comprise a super-elastic alloy.

7. The implantable retainer of Claim 1 wherein at least a portion of said at least one array element is covered by radio-opaque material.

5 8. The implantable retainer of Claim 7 wherein said radio-opaque material is platinum.

9. The implantable retainer of Claim 1 wherein when said retainer assembly is in said second deployed shape, each of said at least one array element terminates remotely
10 from said joint.

10. The implantable retainer of Claim 1 wherein said retainer assembly further comprises a plurality of exterior array elements which open proximally of said at least one array element.
15

11. The retainer element of Claim 10 wherein said exterior array elements open distally of the proximate end of the array element.

12. The implantable retainer of Claim 10 wherein said exterior array elements are
20 located generally perpendicular to said joint.

13. The implantable retainer of Claim 1 wherein said proximal deployed end is distal of said proximal delivery end when the retainer assembly is in the second deployed shape.
25

14. The implantable retainer of Claim 10 wherein said proximal deployed end is distal of said proximal delivery and when the retainer assembly is in the second deployed shape.

15. The implantable retainer of Claim 1 wherein said secondary form approximates the shape of a vascular aneurysm.
30

16. The implantable retainer of Claim 10 wherein said retainer assembly encloses a volume and wherein said implantable retainer contains a helically wound vaso-occlusive device.

5 17. An apparatus for use within a body lumen comprising:
 a wire;
 a selective detachable joint;
 an expandable cage, said joint coupling said cage to said wire; said
 expandable cage capable of assuming a collapsed and expanded configuration,
10 said expanded configuration being self-assumed by said cage when said cage is
 freed of confinement,
 whereby, said cage expands for deployment within said body lumen.

15 18. The apparatus of Claim 17 further comprising a catheter, said wire and
 expandable cage being selectively disposable within said catheter when said cage assumes
 said collapsed configuration and selectively disposable outside of said catheter wherein
 said cage assumes said expanded configuration.

20 19. The apparatus of Claim 18 wherein said body lumen includes at least one coil
 disposed therein and wherein said cage retains said coil within said body lumen when said
 cage is in said expanded configuration.

25 20. The apparatus of Claim 19 wherein said body lumen is an aneurysm and said
 catheter being used to position said cage into said aneurysm, said cage assuming said
 expanded configuration as such cage is being disposed from said catheter into said
 aneurysm, said coil being disposed in said aneurysm and retained therein by said cage.

30 21. The apparatus of Claim 18 wherein said body lumen is a vessel and said free
 coil is disposed in said vessel, said cage capturing said free coil in said vessel when said
 cage is in said expanded configuration to allow said captured free coil to be removed with
 said cage from said vessel.

22. The apparatus of Claim 17 wherein said cage is comprised of a plurality of wires having a memory so that when said cage is free of confinement, it assumes a prebiased shape memorized by said plurality of wires.

5 23. The apparatus of Claim 22 wherein said cage is comprised of a plurality of wires in the form of a cylindrical barrel.

24. The apparatus of Claim 23 wherein said cylindrical barrel cage has a bottom and top apex where said plurality of wires are commonly joined together.

10

25. The apparatus of Claim 17 wherein said detachable joint is electrolytically disintegrated to detach said wire from said cage.

15 26. The apparatus of Claim 17 wherein said detachable joint is an electrolytically disintegratable region.

27. The apparatus of Claim 25 wherein said detachable joint is an electrolytically disintegratable bead.

20 28. The apparatus of Claim 26 wherein said electrolytically disintegratable region comprises a flexible electrolytically disintegratable coil coupled between said wire and said cage.

25 29. The apparatus of Claim 28 wherein said electrolytically disintegratable region further comprises a tapered tip of said wire extending through said coil and coupled to said cage.

30 30. The apparatus of Claim 17 wherein said cage comprises a plurality of wire, each wire having two ends, one end of each said wires being coupled together in a common apex and opposing ends of which are free, said opposing free end forming a curved hook shape.

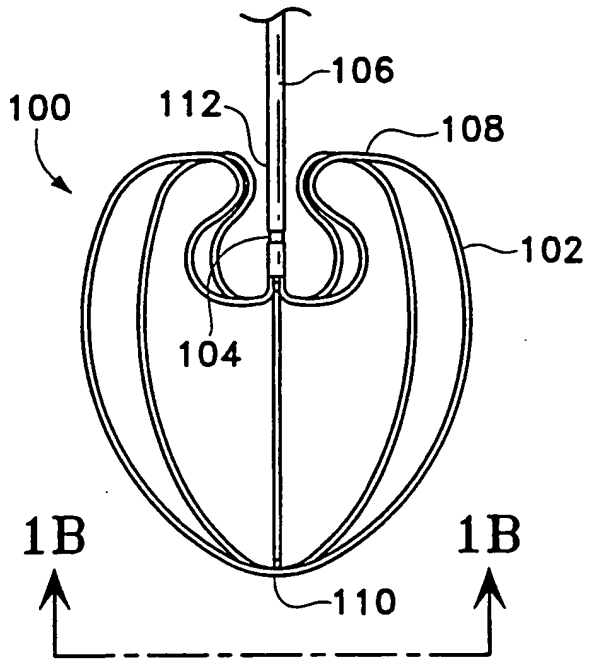

Fig. 1A

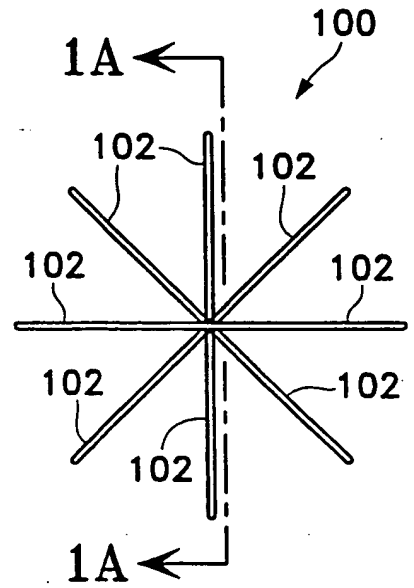

Fig. 1B

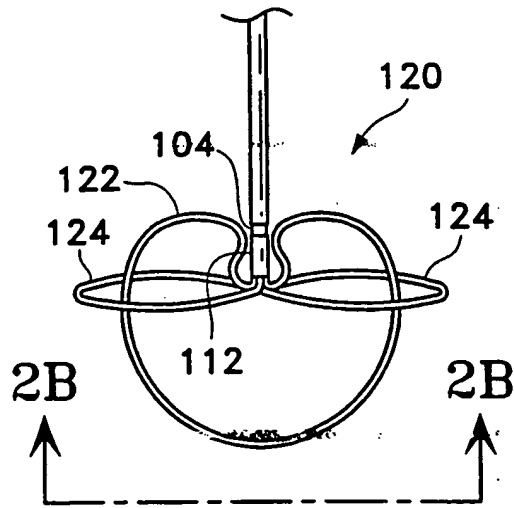

Fig. 2A

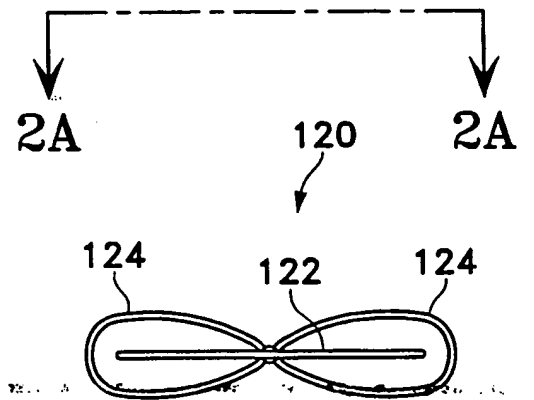

Fig. 2B

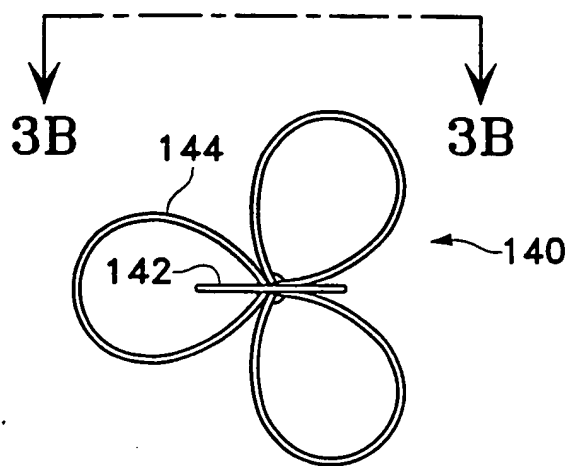

Fig. 3A

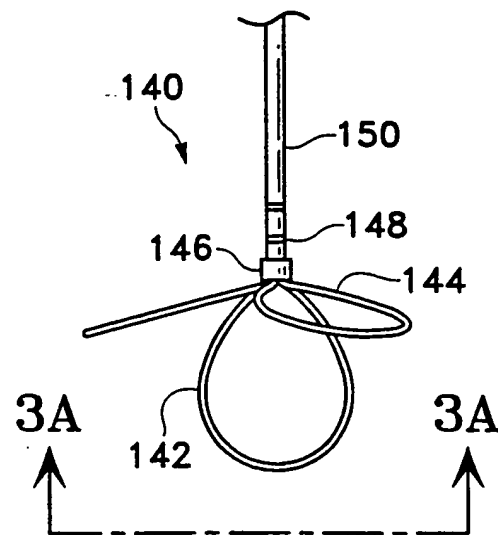

Fig. 3B

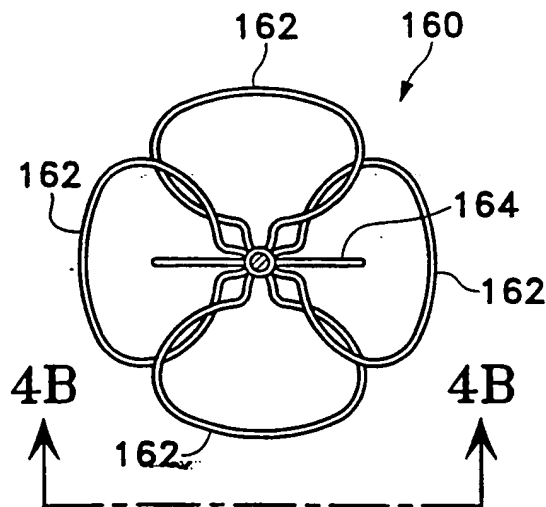

Fig. 4A

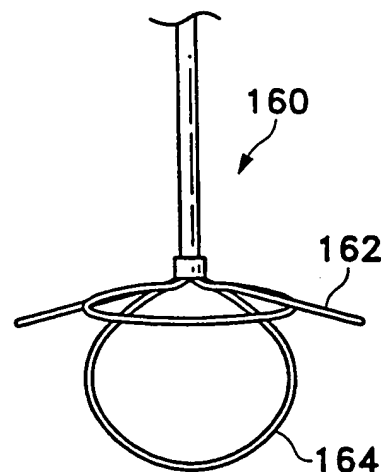

Fig. 4B

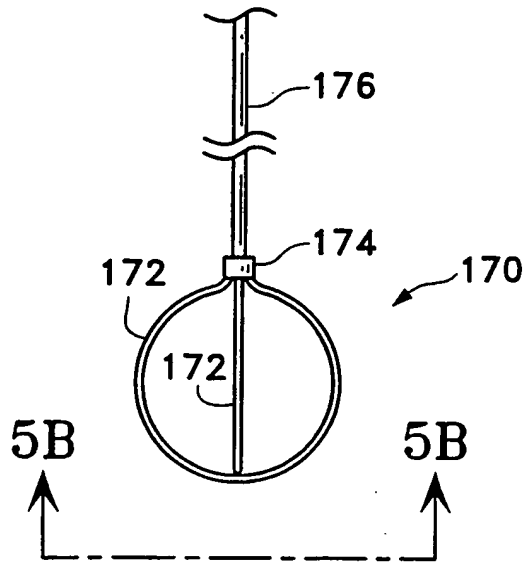

Fig. 5A

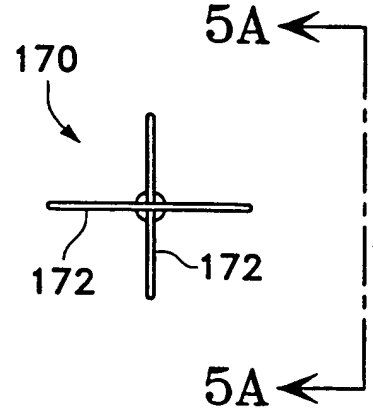

Fig. 5B

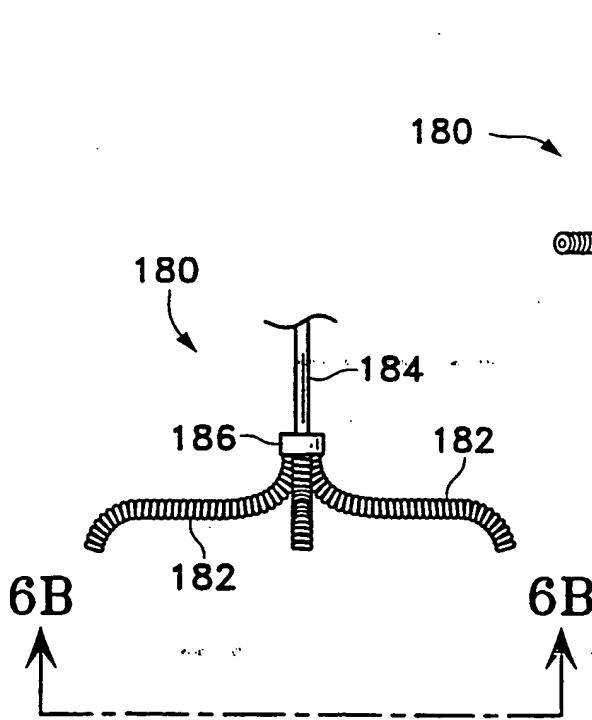

Fig. 6A

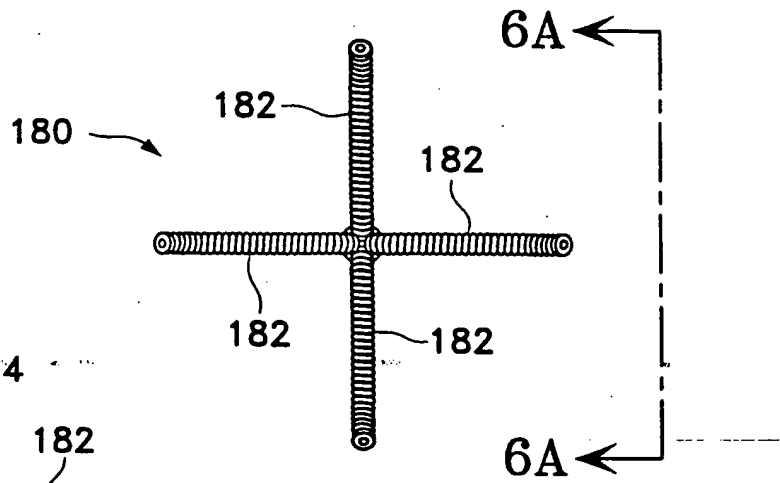

Fig. 6B

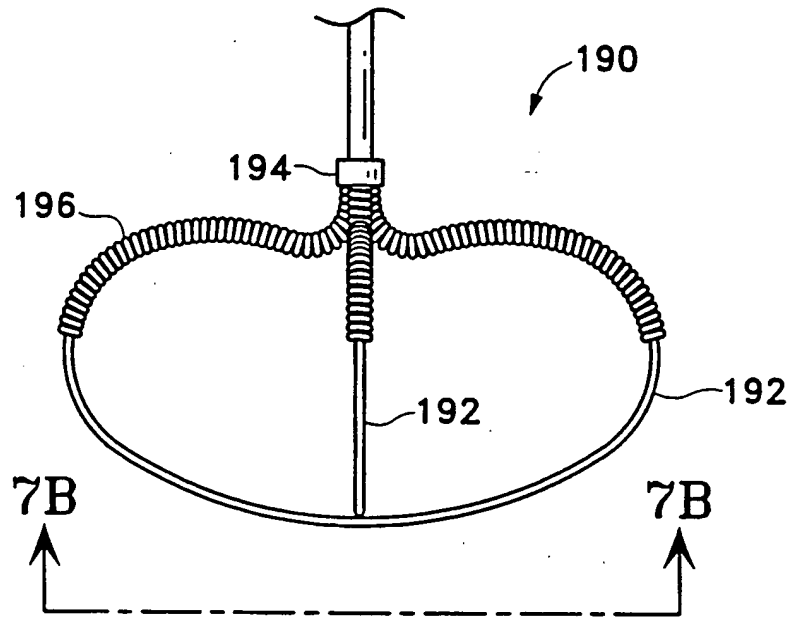

Fig. 7A

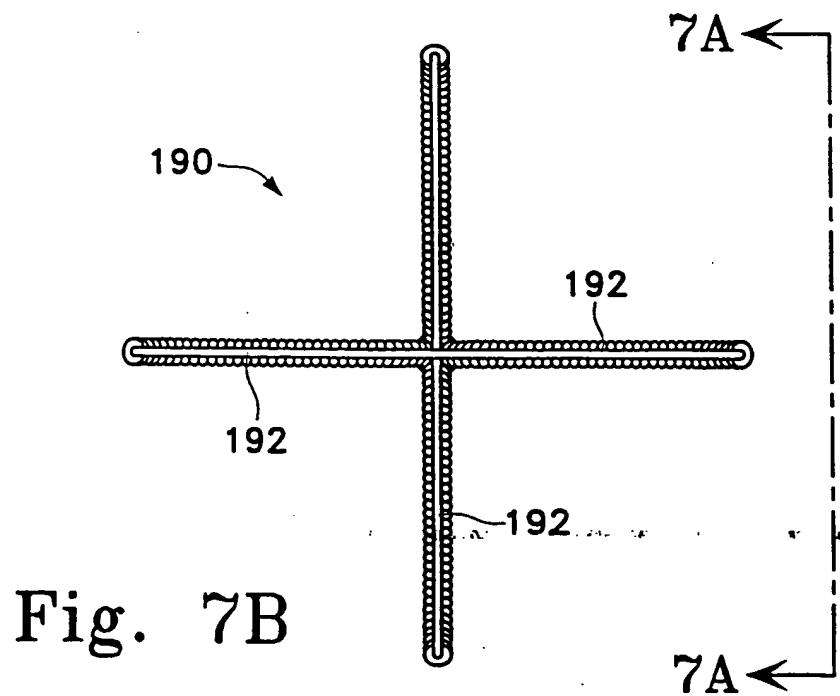

Fig. 7B

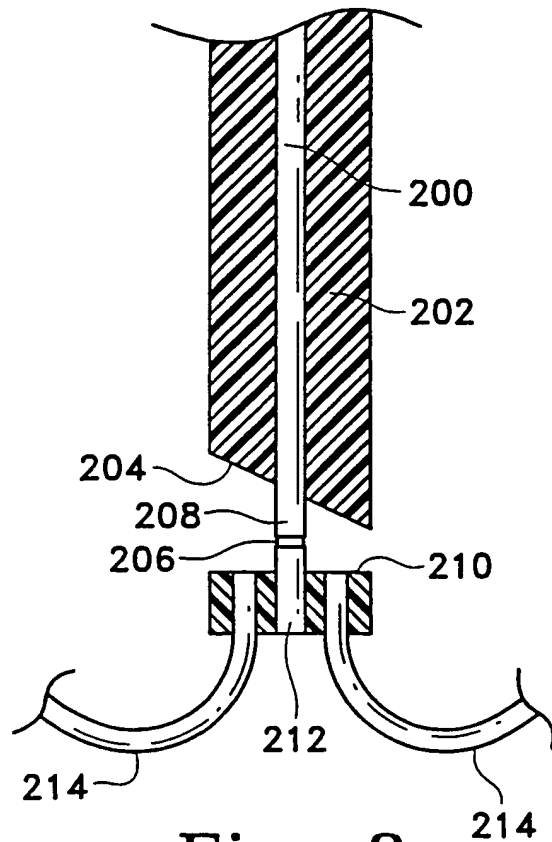

Fig. 8

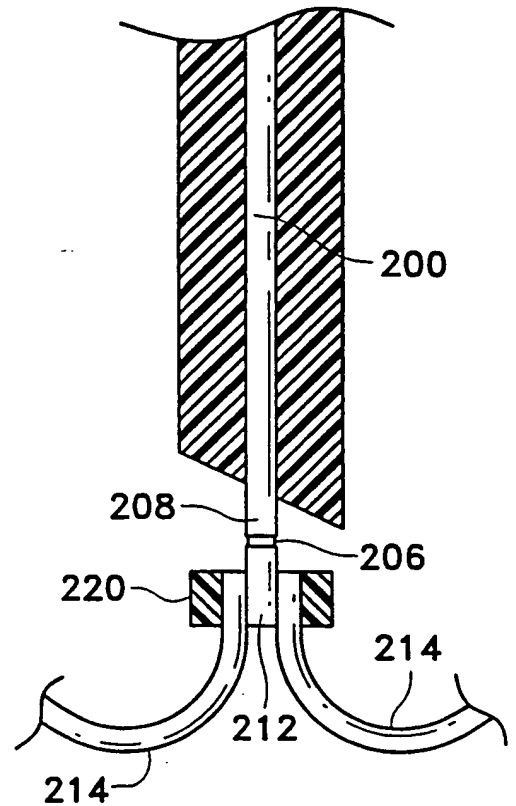

Fig. 9

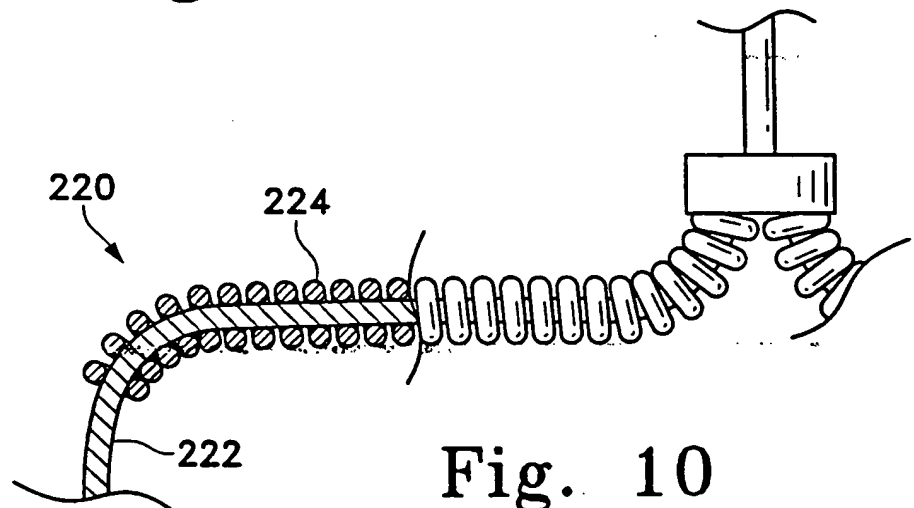

Fig. 10

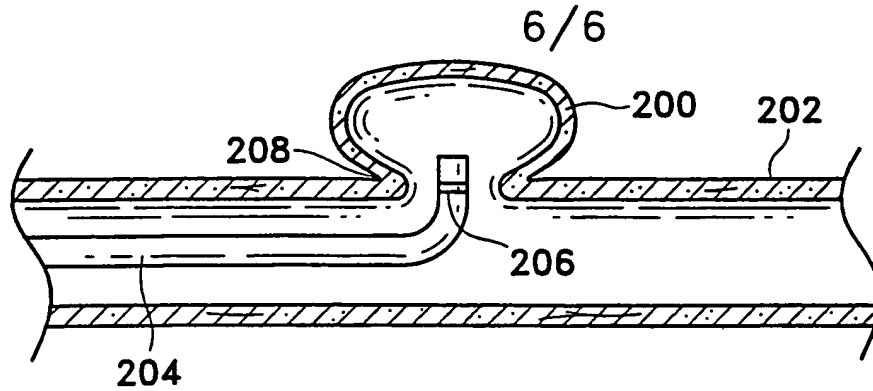

Fig. 11A

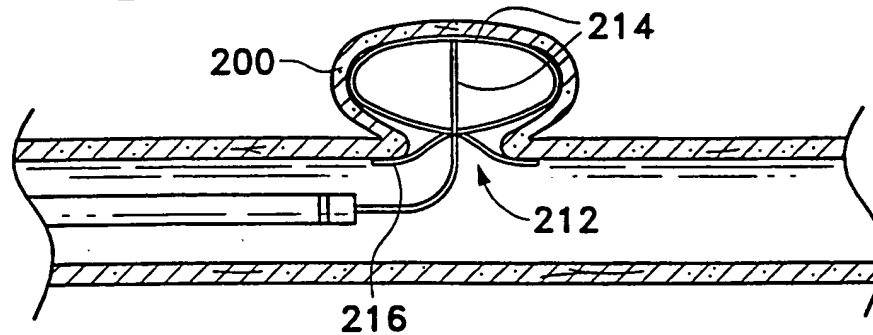

Fig. 11B

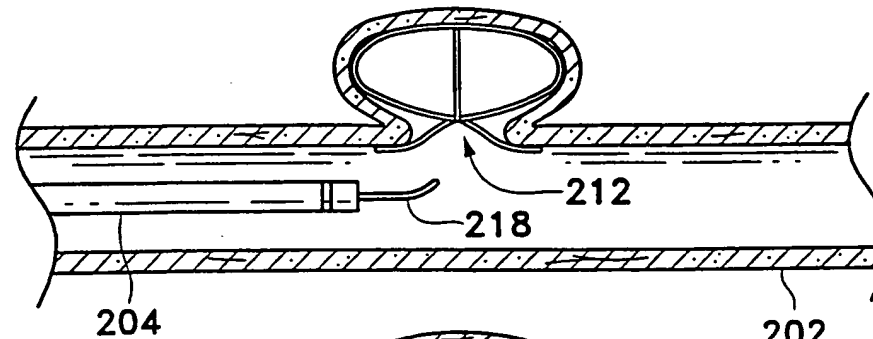

Fig. 11C

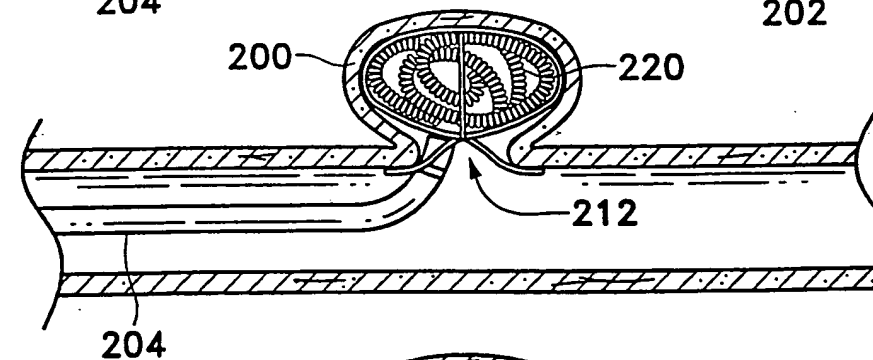

Fig. 11D

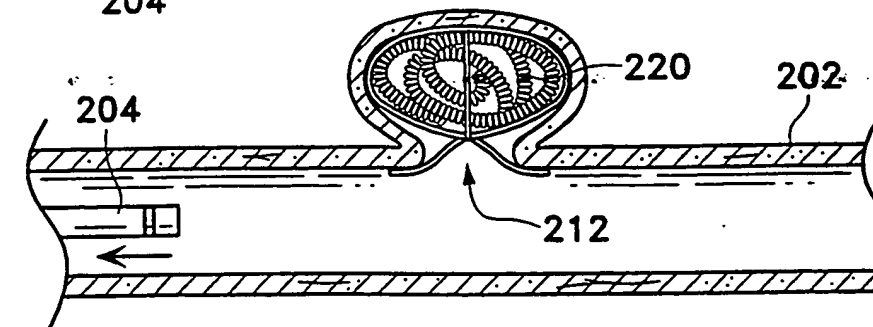

Fig. 11E

SUBSTITUTE SHEET (RULE 26)

INTERNATIONAL SEARCH REPORT

International Application No

PCT/US 98/16367

A. CLASSIFICATION OF SUBJECT MATTER IPC 6 A61B17/12		
According to International Patent Classification (IPC) or to both national classification and IPC		
B. FIELDS SEARCHED		
Minimum documentation searched (classification system followed by classification symbols) IPC 6 A61B		
Documentation searched other than minimum documentation to the extent that such documents are included in the fields searched		
Electronic data base consulted during the international search (name of data base and, where practical, search terms used)		
C. DOCUMENTS CONSIDERED TO BE RELEVANT		
Category ^a	Citation of document, with indication, where appropriate, of the relevant passages	Relevant to claim No.
X A X A A A A A	WO 97 26939 A (MICROVENA) 31 July 1997 see page 22, paragraph 3; figure 6 --- DE 94 13 645 U (SCHNEIDT) 27 October 1994 see figures 2,4 --- EP 0 719 522 A (TARGET) 3 July 1996 see the whole document --- US 4 710 192 A (LIOTTA) 1 December 1987 see figures 2B,3 --- DD 233 303 A (HUMBOLT) 26 February 1986 --- FR 2 678 508 A (CELSA) 8 January 1993 -----	17, 18, 22-24 1 17, 30 1 1, 25 1, 30
<input type="checkbox"/> Further documents are listed in the continuation of box C.		
<input checked="" type="checkbox"/> Patent family members are listed in annex.		
* Special categories of cited documents : "A" document defining the general state of the art which is not considered to be of particular relevance "E" earlier document but published on or after the international filing date "L" document which may throw doubts on priority claim(s) or which is cited to establish the publication date of another citation or other special reason (as specified) "O" document referring to an oral disclosure, use, exhibition or other means "P" document published prior to the international filing date but later than the priority date claimed "T" later document published after the international filing date or priority date and not in conflict with the application but cited to understand the principle or theory underlying the invention "X" document of particular relevance; the claimed invention cannot be considered novel or cannot be considered to involve an inventive step when the document is taken alone "Y" document of particular relevance; the claimed invention cannot be considered to involve an inventive step when the document is combined with one or more other such documents, such combination being obvious to a person skilled in the art. "&" document member of the same patent family		
Date of the actual completion of the international search		Date of mailing of the international search report
10 November 1998		17/11/1998
Name and mailing address of the ISA European Patent Office, P.B. 5818 Patentlaan 2 NL - 2280 HV Rijswijk Tel. (+31-70) 340-2040, Tx. 31 651 epo nl, Fax: (+31-70) 340-3016		Authorized officer Barton, S

INTERNATIONAL SEARCH REPORT

International application No.

PCT/US 98/ 16367

Box I Observations where certain claims were found unsearchable (Continuation of item 1 of first sheet)

This International Search Report has not been established in respect of certain claims under Article 17(2)(a) for the following reasons:

- 1. Claims Nos.:
because they relate to subject matter not required to be searched by this Authority, namely:

- 2. Claims Nos.:
because they relate to parts of the International Application that do not comply with the prescribed requirements to such an extent that no meaningful International Search can be carried out, specifically:

- 3. Claims Nos.:
because they are dependent claims and are not drafted in accordance with the second and third sentences of Rule 6.4(a).

Box II Observations where unity of invention is lacking (Continuation of item 2 of first sheet)

This International Searching Authority found multiple inventions in this international application, as follows:

- 1. As all required additional search fees were timely paid by the applicant, this International Search Report covers all searchable claims.

- 2. As all searchable claims could be searched without effort justifying an additional fee, this Authority did not invite payment of any additional fee.

- 3. As only some of the required additional search fees were timely paid by the applicant, this International Search Report covers only those claims for which fees were paid, specifically claims Nos.:

- 4. No required additional search fees were timely paid by the applicant. Consequently, this International Search Report is restricted to the invention first mentioned in the claims: it is covered by claims Nos.:

Remark on Protest

The additional search fees were accompanied by the applicant's protest.

No protest accompanied the payment of additional search fees.

INTERNATIONAL SEARCH REPORT

Information on patent family members

International Application No
PCT/US 98/16367

Patent document cited in search report	Publication date	Patent family member(s)	Publication date
WO 9726939 A	31-07-1997	CA 2194671 A	25-01-1996
		EP 0769926 A	02-05-1997
		JP 10504738 T	12-05-1998
		WO 9601591 A	25-01-1996
DE 9413645 U	27-10-1994	DE 29500381 U	20-07-1995
		EP 0698373 A	28-02-1996
EP 719522 A	03-07-1996	AU 4077496 A	11-07-1996
		CA 2166142 A	01-07-1996
		EP 0861634 A	02-09-1998
		JP 2641715 B	20-08-1997
		JP 8252323 A	01-10-1996
US 4710192 A	01-12-1987	NONE	
DD 233303 A	26-02-1986	NONE	
FR 2678508 A	08-01-1993	NONE	